

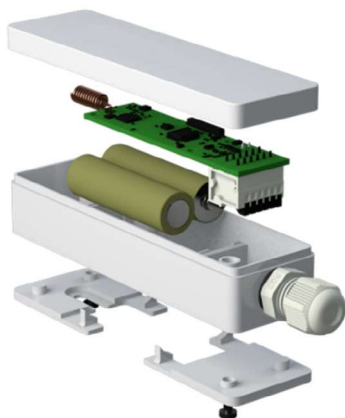

LOW COST LORA SENSOR REFERENCE DESIGNS



The Lora sensor reference design has been designed to provide low cost production ready product.

The multiple analog and digital interfaces allow versatile device use cases :
Temperature, Humidity, leak, pulse counter metering, luminosity, 4-20mA sensors and more...

FEATURES

- Can run 20 years on 2 AA batteries
- Internal or external Lora antennas
- Can be used on private or Telco Lora networks
- Integrated Temperature sensor
- Integrated accelerometer and magnetic switch
- 1uA Standby power consumption
- Communication > 10 km with no direct Field of View
- BOM Highly Optimized
- 1 side PCB
 - └ Lora Chipset solution (SX1272)
 - └ STM32 Memory optimizations
 - └ RBOM Optimisations

Optimized Lora Stack

- └ Very high power optimization for some specific use cases (for example for metering) with help of external clock
- └ Reduction of the number of bit sent
- └ Reduction of STM32 memory requirements

Compatible with Cayenne

Product Size in mm (without external antennas) :
 33 x 115 x 28

Operating temperature : -20 to +55 DEGC

RF Sensitivity : -137 DBm

RF Power : + 20 dBm

Temperature accuracy : +/- 0,2 DEGC

Radio band : 868 MHz (LORA)

BLOCK DIAGRAM

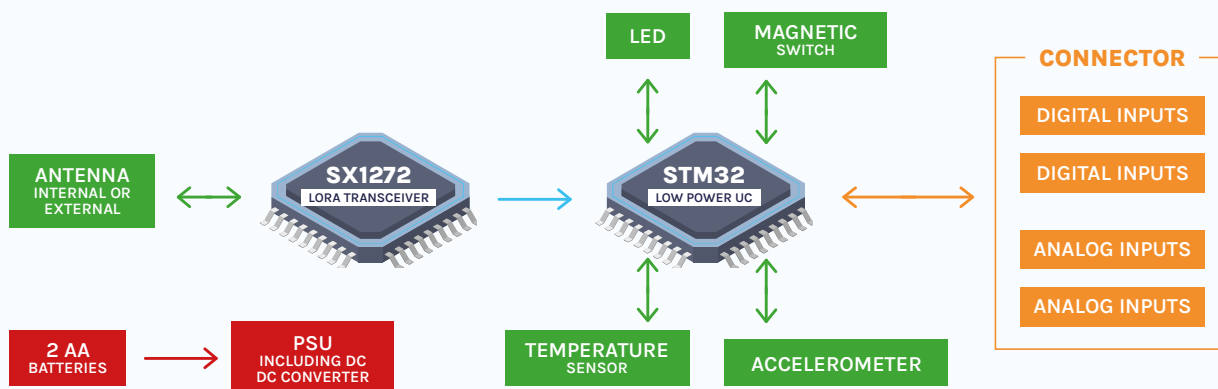

DELIVERY

- | | |
|--|----------------------|
| Schematics | STM32 Firmware |
| Layout | SX1272 Configuration |
| eBOM | |
| <ul style="list-style-type: none"> └ Production files (PCB Structure, Component placements for SMT production machines..) └ Test program with test bench for manufacturing | |

ASSOCIATED SERVICES

We can provide customization services either on the hardware or on the embedded software or on the mechanical design.

We can manage for you the EMS in charge of the production of the device.